

---

INSTRUCTION BOOK

OPERATING INSTRUCTIONS

**MULTI-PURPOSE  
THRULINE<sup>®</sup> WATTMETER  
RF POWER ANALYST<sup>®</sup>  
MODEL 4391A**

**BIRD**

**Electronic Corporation**

Cleveland, (Solon) Ohio USA

---

© Copyright 1997 by Bird Electronic Corporation  
Instruction Book Part Number 920-4391A Rev. D  
Thruline<sup>®</sup> and Power Analyst<sup>®</sup> are Registered  
Trademarks of Bird Electronic Corporation



---

## Safety Precautions

The following are general safety precautions that are not necessarily related to any specific part or procedure and do not necessarily appear elsewhere in this publication. These precautions must be thoroughly understood and apply to all phases of operation and maintenance.

### Keep Away From Live Circuits

Operating personnel must at all times observe general safety precautions. Do not replace components or make adjustments to the inside of equipment with the high voltage supply turned on. To avoid casualties, always remove power.

### Do Not Service Or Adjust Alone

Under no circumstances should any person reach into an enclosure for the purpose of service or adjustment of equipment except in the presence of someone who is capable of rendering aid.

### Shock Hazard

Do not attempt to disconnect an RF transmission line while RF power is present. Radiated RF power is a potential health hazard.

### Chemical Hazard

Dry cleaning solvents used to clean parts may be potentially dangerous. Avoid inhalation of fumes and also prolonged contact with skin.

### Resuscitation

Personnel working with or near high voltages should be familiar with modern methods of resuscitation.

### Safety Symbols

**WARNING**

Warning notes call attention to a procedure, which if not correctly performed, could result in personal injury.

CAUTION

Caution notes call attention to a procedure, which if not correctly performed, could result in damage to the instrument.



This symbol appears on the equipment indicating there is important information in the instruction manual regarding that particular area. The following information appears in the text and is repeated here for emphasis

**Fuse Replacement**

Always use the same type and rating of fuse when replacing the fuse. Fuse information can be found in the replacement parts list on page 29.

 Note: Calls attention to supplemental information.

**Warning Statements**

The following safety warnings appear in the text and are repeated here for emphasis.

WARNING

Units are equipped with rechargeable batteries. These are to be replaced by authorized service personnel only.

WARNING

Be sure that the power cable is unplugged before opening the wattmeter case. The power supply capacitor, C11, can retain a dangerous charge that must be removed before touching. Always have another person standing by who is trained in electric shock first aid.

**Caution Statements**

The following equipment cautions appear in the text and are repeated here for emphasis.

CAUTION

Never apply RF power to the Model 4391A Wattmeter unless both line section sockets are filled with either an element or a dust plug. If an element is used it is advisable to place the element with the arrow at a 90° angle to the coaxial line.

CAUTION

Always disconnect ac power before opening the Model 4391A enclosure.

---

Removal of at least one battery cell is also recommended when servicing the instrument.

**CAUTION**

The Model 4391A Wattmeter contains MOS (metal oxide semiconductor) integrated circuits which may be damaged by static electricity. Open the housing only when sure that there are no static producing materials such as carpeting or styrofoam where the work is to be done. Work on a conductive, grounded work surface touching it frequently to discharge static from your body. If a part is to be stored or shipped, wrap it in conductive packaging materials designed for static sensitive circuitry.

**CAUTION**

Always be certain the 115/230 voltage selector is set to the proper voltage before ac power is applied.

**Safety Statements**



**USAGE**

ANY USE OF THIS INSTRUMENT IN A MANNER NOT SPECIFIED BY THE MANUFACTURER MAY IMPAIR THE INSTRUMENT'S SAFETY PROTECTION.

**USO**

EL USO DE ESTE INSTRUMENTO DE MANERA NO ESPECIFICADA POR EL FABRICANTE, PUEDE ANULAR LA PROTECCIÓN DE SEGURIDAD DEL INSTRUMENTO.

**BENUTZUNG**

WIRD DAS GERÄT AUF ANDERE WEISE VERWENDET ALS VOM HERSTELLER BESCHRIEBEN, KANN DIE GERÄTESICHERHEIT BEEINTRÄCHTIGT WERDEN.

**UTILISATION**

TOUTE UTILISATION DE CET INSTRUMENT QUI N'EST PAS EXPLICITEMENT PRÉVUE PAR LE FABRICANT PEUT ENDOMMAGER LE DISPOSITIF DE PROTECTION DE L'INSTRUMENT.

**IMPRIEGO**

QUALORA QUESTO STRUMENTO VENISSE UTILIZZATO IN MODO DIVERSO DA COME

SPECIFICATO DAL PRODUTTORE LA PROZIONE DI SICUREZZA POTREBBE VENIRNE COMPROMESSA.

SERVICE



SERVICING INSTRUCTIONS ARE FOR USE BY SERVICE -TRAINED PERSONNEL ONLY. TO AVOID DANGEROUS ELECTRIC SHOCK, DO NOT PERFORM ANY SERVICING UNLESS QUALIFIED TO DO SO.

SERVICIO

LAS INSTRUCCIONES DE SERVICIO SON PARA USO EXCLUSIVO DEL PERSONAL DE SERVICIO CAPACITADO. PARA EVITAR EL PELIGRO DE DESCARGAS ELÉCTRICAS, NO REALICE NINGÉN SERVICIO A MENOS QUE ESTÉ CAPACITADO PARA HACERLO.

WARTUNG

ANWEISUNGEN FÜR DIE WARTUNG DES GERÄTES GELTEN NUR FÜR GESCHULTES FACHPERSONAL.

ZUR VERMEIDUNG GEFÄHRLICHE, ELEKTRISCHE SCHOCKS, SIND WARTUNGSARBEITEN AUSSCHLIEBLICH VON QUALIFIZIERTEM SERVICEPERSONAL DURCHZUFÜHREN.

ENTRETIEN

L'EMPLOI DES INSTRUCTIONS D'ENTRETIEN DOIT ÊTRE RÉSERVÉ AU PERSONNEL FORMÉ AUX OPÉRATIONS D'ENTRETIEN. POUR PRÉVENIR UN CHOC ÉLECTRIQUE DANGEREUX, NE PAS EFFECTUER D'ENTRETIEN SI L'ON N'A PAS ÉTÉ QUALIFIÉ POUR CE FAIRE.

ASSISTENZA TECNICA

LE ISTRUZIONI RELATIVE ALL'ASSISTENZA SONO PREVISTE ESCLUSIVAMENTE PER IL PERSONALE OPPORTUNAMENTE ADDESTRATO. PER EVITARE PERICOLOSE SCOSSE ELETTRICHE NON EFFETTUARE ALCUNA RIPARAZIONE A MENO CHE QUALIFICATI A FARLA.



UNITS ARE EQUIPPED WITH RECHARGEABLE BATTERIES. THESE ARE TO BE REPLACED BY AUTHORIZED SERVICE PERSONNEL ONLY!!!

LAS UNIDADES VIENEN EQUIPADAS CON BATERIAS RECARGABLES. ¡¡¡Y SOLAMENTE EL PERSONAL DE SERVICIO AUTORIZADO PUEDE REEMPLAZARLAS!!!

GERÄTE SIND MIT WIEDER AUFLADBAREN BATTERIEN BESTÜCKT. BATTERIEN SIND NUR VON QUALIFIZIERTEM SERVICE PERSONAL AUSZUWECHSELN!!!

CES DISPOSITIFS SONT ÉQUIPÉS DE BATTERIES RECHARGEABLES. SEUL LE PERSONNEL D'ENTRETIEN AUTORISÉ EST HABILITÉ À LES REMPLACER !

LE UNITÀ SONO DOTATE DI BATTERIE RICARICABILI, CHE DEVONO DA COME SPECIFICATO DAL PRODUTTORE LA PROTEZIONE DI SICUREZZA POTREBBE VENIRNE COMPROMESSA.

USE CORRECT VOLTAGE SETTING AND FUSE - SEE MANUAL.



UTILISER UNE TENSION ET UN FUSIBLE CORRECTS - CONSULTER LE MODE D'EMPLOI.

USE LA INSTALACION Y FUSIBLE DE VOLTAJE CORRECTO - VEA EL MANUAL.

AUSSCHLIESSLICH VORSCHRIFTSMÄSSIGE WECHSELSPANNUNGS-EINSTELLUNG UND SICHERUNG BENUTZEN - SIEHE DAZU HANDBUCH.

UTILIZZARE TENSIONE E FUSIBILE ADATTI - FARE RIFERIMENTO AL MANUALE.

BE SURE THE 115/230V AC VOLTAGE SELECTOR IS SET TO THE PROPER LINE VOLTAGE, AND THE CORRECT AC LINE FUSE IS INSTALLED BEFORE AC POWER IS APPLIED.



S'ASSURER QUE LE SÉLECTEUR DE TENSION 115/230V C.A. EST BIEN RÉGLÉ POUR LA TENSION DU RÉSEAU ET QUE LE FUSIBLE DE LIGNE C.A. CORRECT EST EN PLACE AVANT DE METTRE SOUS TENSION C.A.

CERCIORESE QUE EL SELECTOR DE VOLTAJE DE 115/230V CA ESTE COLOCADO A LA LINEA DE VOLTAJE APROPIADA Y QUE EL FUSIBLE ESTE INSTALADO A LA LINEA CA ANTES DE APLICAR LA CORRIENTE ALTERNA.

VOR EINSCHALTEN DER WECHSELSTROMZUFUHR SICHERSTELLEN, DASS DER 115/230V WECHSELSPANNUNGS-SELEKTOR AUF DIE VORSCHRIFTSMÄSSIGE LEITUNGSSPANNUNG EINGESTELLT UND DIE RICHTIGE WECHSELSTROM-HAUPTSICHERUNG EINGESETZT IST.

PRIMA DI EROGARE CORRENTE, ASSICURARSI CHE IL SELETTORE DI VOLTAGGIO 115/230 V.C.A. SIA REGOLATO CORRETTAMENTE E CHE IL FUSIBLE ADATTO ALLA LINEA DI ALIMENTAZIONE C.A. SIA INSTALLATO.



RF VOLTAGE MAY BE PRESENT IN RF ELEMENT SOCKET - KEEP ELEMENT IN SOCKET DURING OPERATION.

DE LA TENSION H.F. PEAT ÊTRE PRÉSENTE DANS LA PRISE DE L'ÉLÉMENT H.F. -CONSERVER L'ÉLÉMENT DANS LA PRISE LORS DE L'EMPLOI.

HF-SPANNUNG KANN IN DER HF-ELEMENT-BUCHSE ANSTEHEN -ELEMENT WÄHREND DES BETRIEBS EINGESTÖPSELT LASSEN.

PUEDE HABER VOLTAJE RF EN EL ENCHUFE DEL ELEMENTO RF -MANTENGA EL ELEMENTO EN EL ENCHUFE DURANTE LA OPERACION.

IL PORTAELEMENTO RF PUÒ PRESENTARE VOLTAGGIO RF - TENERE L'ELEMENTO NELLA PRESA DURANTE IL FUNZIONAMENTO.



---

## About This Manual

This instruction book is arranged so that essential information on safety is contained in the front of the book. Reading the Safety Precautions Section before operating the equipment is strongly advised.

The remainder of this Instruction Book is divided into Chapters and Sections. Figures and tables are numbered sequentially within each chapter.

**Operation** First time operators should read Chapter 1 - Introduction, and Chapter 3 - Preparation for Use, to get an overview of equipment capabilities and how to install it. An experienced operator can refer to Chapter 4 - Operating Instructions. All instructions necessary to operate the equipment, are contained in this section.

**Maintenance** All personnel should be familiar with calibration and repair information found in Chapter 5 - Maintenance. If a failure should occur, the troubleshooting section will aid in isolating and repairing the failure.

**Parts** For location of major assemblies or parts refer to the part lists and associated drawings in Chapter 5.

**Changes** Changes to this publication will be made as required. To keep your instruction book accurate and up to date, it is recommended that a periodic request of the latest revision be made. It will be supplied at no cost. When requesting updates, reference your instruction book part number and its revision level listed on the title page.

**Reporting Errors** It is our goal to provide our users with the information needed to operate and maintain the Model 4391A. If you should discover any errors in this publication or if you have suggestions for improving this instruction book, please send your comments to our factory.



---

# Table Of Contents

- Safety Precautions . . . . . i**
  - Warning Statements . . . . . ii
  - Caution Statements . . . . . ii
  - Safety Statements . . . . . iii
  - About This Manual . . . . . vii
  
- Introduction . . . . . 1**
  - Purpose and Function . . . . . 1
  - Description . . . . . 2
- Specifications . . . . . 3
  - Specification Notes . . . . . 4
  
- Theory Of Operation . . . . . 5**
  - Description of Operation . . . . . 5
  - Keyboard, Range Switches, and Display Group . . . . . 6
  - Plug-in Elements, Analog Circuitry, and A/D Converter . . . . . 6
  
- Installation. . . . . 9**
  - Connections . . . . . 9
  
- Operating Instructions . . . . . 11**
  - Operating Modes . . . . . 11
  - Reading Forward Power . . . . . 11
  - Reading Reflected CW Power . . . . . 13
  - Reading SWR . . . . . 13
  - Measuring Peak Envelope Power. . . . . 15
  - Measuring Amplitude Modulation . . . . . 15

**ix**

Measuring Power in dBm . . . . .	17
Measuring Return Loss, Insertion Loss, or Attenuation . . . . .	18
Monitoring Maximum and Minimum Readings . . . . .	19
Using the Peaking Aid . . . . .	19
Operating on AC Power . . . . .	20
<b>Maintenance . . . . .</b>	<b>21</b>
Service Center . . . . .	21
Sales Offices . . . . .	21
Troubleshooting. . . . .	22
Worn or Damaged Connectors . . . . .	22
Worn Element Seats . . . . .	22
Intermittent Contact . . . . .	22
Loose Catches. . . . .	22
No Output From One Socket . . . . .	22
Short Battery Life . . . . .	22
Unit Will Not Operate at All Under Battery Power. . . . .	23
Does Not Function In Line Position . . . . .	23
Key Does Not Make Contact . . . . .	23
Row or Column of Keys Not Working . . . . .	23
One Segment on One Digit Out . . . . .	23
Entire Digit Malfunction . . . . .	23
Same Segment on All Digits Malfunctioning . . . . .	23
No Decimal Point or All Decimal Points . . . . .	23
Strange Counting Sequence . . . . .	23
Disassembly . . . . .	24
Front Panel Removal. . . . .	24

---

Removing the Line Section . . . . .	24
Removing the Line Section PC Board. . . . .	24
Decreasing the Settling Time . . . . .	24
Calibration . . . . .	25
Repair . . . . .	25
Battery Replacement. . . . .	26
Battery Care . . . . .	27
Replacement Parts List . . . . .	29



The Model 4391A is a multi-purpose Radio Frequency wattmeter designed around a microcomputer. A program stored in permanent memory controls the operation of the instrument at all times, permitting the detection and correction of various error sources and the refinement of the raw data produced by the directional detectors. The instrument can compute VSWR, amplitude modulation, and various decibel variables reducing the odds of error and making such measurements consistent or repeatable regardless of who is making the measurement.

Other benefits include extended range using standard elements in some modes of operation, continuous monitoring of maximum and minimum readings, a peaking aid, and error messages.

Because of its complexity, the proper use of the 4391A is not always obvious. For this reason it is strongly advised that this manual be read in its entirety before using the device.

### **Purpose and Function**

The 4391A RF Power Analyst is an insertion type digital RF Directional Thru-line Wattmeter designed to measure peak or average power flow, load match, and amplitude modulation in 50 ohm coaxial transmission lines. It is intended for use with CW, AM, FM, SSB, TV, and Pulse modulation envelopes. The instrument directly reads PEP or CW power in watts, milliwatts, or kilowatts in 9 ranges from 2.5 to 1000 full scale forward power and 0.25 to 100 full scale reflected power depending on the Plug-in Element. In addition it reads SWR directly over the range of 1.00 to 99.99, percent modulation directly over the range of .0 to 99.9, and return loss over the range of 0 to 36.1 dB. For convenience, forward and reflected CW power can be displayed in dBm (dB above 1 milliwatt) from 6 dB above to 24 dB below nominal element range.

Power range and frequency band are determined by the Plug-in Elements used. Two switches on the front panel of the instrument are set by the user to correspond to the nominal power range of the forward element. The reflected element is assumed to have a nominal range one tenth that of the forward element.

In any of the modes of operation described, the instrument can recall from memory the lowest or highest reading taken or tell the operator whether the newest reading is less than, equal to, or greater than the previous reading.

**Description**

The instrument is housed in an aluminum calculator-style case approximately 4-3/8 inches high by 9-5/8 inches deep by 6-1/4 inches wide (111 mm x 244 mm x 159 mm) including connections, see figure 1. The line section is contained in the case and is not intended for removal. At each end of the line section are Bird Quick-Change type RF connectors which may be easily interchanged with any other Bird QC connector. See Bird Catalog for types available.

Operating power is derived from rechargeable nickel-cadmium batteries inside the unit or from a 115/230 Vac power source connected to the unit through the power cord supplied with the unit.



## Specifications

<b>Measuring Medium</b>	RF Transmission in 50 ohm lines
<b>RF Power Range</b> <sup>1</sup>	100 mW to 10 kW full scale using Bird Plug-in Elements. Accuracy not guaranteed with components not supplied by Bird
<b>Usable Over-Range</b>	To 120% of scale on CW, PEP, SWR, and Return loss functions. To 400% of scale (PEP) on dBm and 0% modulation.
<b>Frequency Range</b> <sup>1</sup>	450 kHz to 2.3 GHz
<b>Sampling Range</b>	2-3 readings per second
<b>Settling Time</b>	10 seconds (worst case) <sup>3</sup>
<b>Accuracy</b>	
Power Readings	±5% of full scale
SWR	±10% of reading
% Modulation	±5% <sup>2</sup>
Return Loss	±0.3 dB to corresponding SWR value
<b>Impedance</b>	50 ohms
<b>Insertion SWR</b>	<b>1.05 max to 1000 MHz</b>
<b>Pulse Parameters</b> (square pulses)	
Pulse Width	0.8 sec min. <sup>4</sup>
Repetition Rate	25 pps min.
Duty Cycle	0.01% min.
<b>RF Line Connections</b>	
Standard	Bird Quick Change "QC" Female N
Optional	Any Standard AN "QC" type
<b>Temperature Range</b>	
Operating	10 C to 45 C (50 F to 113 F)
Storage	-20 C to 45 C (-4 F to 113 F)
<b>Input Power Requirements</b>	
Voltage	100-130 or 200-230 Vac (Switch Selectable) or 7.5 Vdc (internal battery)
Frequency	50-60 Hz
Power	6 Watts
Batteries	6-1.25 V Nicad C size
Battery Life	(Rechargeable) 8 hours approx.
<b>Weight</b>	5-3/4 lb (2.6 kg)

**Specification Notes**

<sup>1</sup> Frequency band and power range is determined by Plug-in Elements selected. See Bird Catalog for availability. Some modes require two elements in a 10:1 power ratio.

<sup>2</sup> For CW power levels greater than one-third of full scale, accuracy of the percent modulation mode is 5% from 0 to 90% and +10% from 90 to 100%. Modulation frequency is 25 to 100,000 Hz; except for "A" and "B" elements: 25 to 20,000 Hz; and "H" elements: 25-10,000 Hz.

<sup>3</sup> VSWR and return loss functions settle in less than 1 second.

<sup>4</sup> For "A" and "B" elements the minimum pulse width is 1.5 microseconds. For "H" elements the minimum pulse width is 15 microseconds.

Figure 1  
Outline Drawing

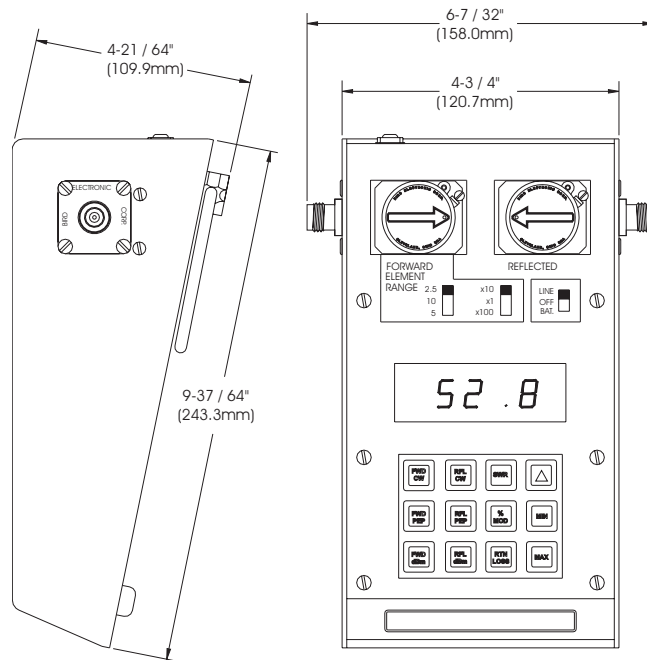

## Chapter 2

## Theory Of Operation

### Description of Operation

Figure 2 is a block diagram of the major functional parts of the Model 4391A RF Wattmeter. The Microcomputer integrated circuit shown, controls all the other portions of the instrument, which fall into two major groups.

Figure 2  
Circuit Block  
Diagram

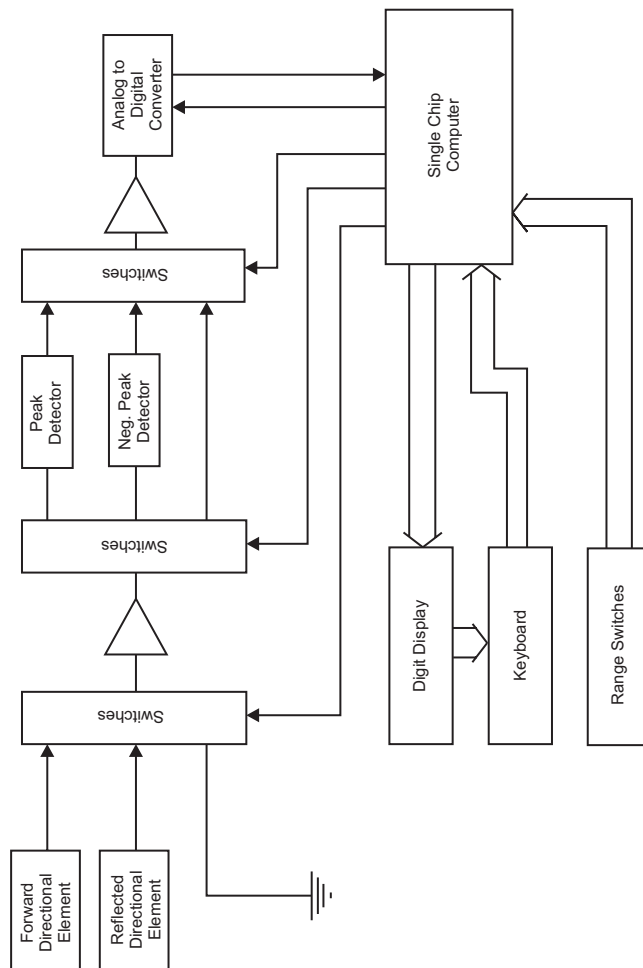

**Keyboard,  
Range  
Switches,  
and Display  
Group**

The keyboard and range switches serve only to pass information to the computer. The display, of course, returns information from the computer to the operator. The display, which is comprised of four seven-segment LED digits, is strobed digit by digit left to right at a rate of approximately one digit per millisecond. This serves to conserve battery power and drive circuitry while providing scanning for the columns of the keyboard. Each time a digit is strobed, the corresponding column of the keyboard is read and if a key is pressed, the computer puts the code for that key into a memory cell. The nine mode keys select which parameter is to be measured. The three modifier keys simply modify the way in which the result is displayed. The range selector switches identify to the computer the nominal full scale values of the elements used. They have no effect on input sensitivity, which is determined by the elements.

**Plug-in Elements, Analog Circuitry, and A/D Converter**

These components are controlled by the computer. The Plug-in Elements in the line section provide low level positive voltages related to the instantaneous value of power (see figure 3). The first group of solid state switches selects the forward element, the reflected element, or ground as the input to the preamplifier which boosts these signals to 0.1 to 2.0 volt range. The remaining switches shown as two groups direct the output of the preamp to the analog-to-digital converter either directly or through a peak or negative peak detector. The analog-to-digital converter converts the voltage to a 15 digit binary number.

Each reading output by the display is derived from as many as three different voltage readings using the circuitry described above. Once these voltages are measured, all the remaining operations are performed within the computer chip as follows:

The voltages are corrected for error due to dc drift in the analog circuitry. Each voltage is converted to square root of power using tables of stored data. These values are then combined mathematically to arrive at the final result in binary. This is used to update the registers containing the last value, the maximum value, or the minimum value as required. Finally, the result is converted to a decimal number and placed into a register from which the display driving routine operates.

Figure 3  
Plug-In Element  
Schematic  
Diagram

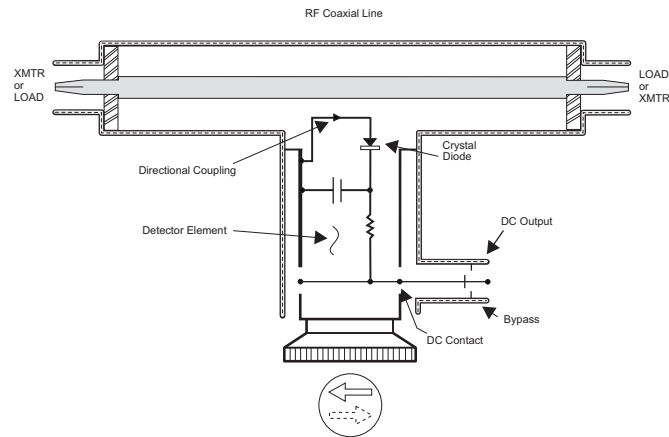

The coupling circuit which samples the travelling waves is in the Plug-in Element. The circuitry of the element and its relationship to the other components of the ThruLine Wattmeter are illustrated in the schematic diagram. Energy will be produced in the coupling circuit of the element by both mutual inductance and capacitance from the travelling RF waves of the line section. The inductive currents will, of course, flow according to the direction of the travelling waves producing them. The capacitive portion of these currents is naturally independent of the direction of the travelling waves. Therefore, assuming that the Plug-in Element remains stationary, it is apparent that the coupling currents produced from the waves of one direction will add in phase, and those produced from waves of the opposite direction will accordingly subtract in phase. The additive or "ARROW" direction is, of course, assigned to the forward wave.

The electrical values of the element circuits are carefully balanced and so designed that the current produced from the reverse wave will cancel the other almost completely. The resultant is a directivity always higher than 25 dB, which means that the element is highly insensitive (nulled) to the REVERSE direction wave. Being highly directional, the ThruLine element is sensitive (at one setting) only to one of the travelling waves which produces standing waves by interference. ThruLine Wattmeter measurements are, therefore, independent of position along standing waves.

Figure 4  
Readings  
with Various  
Envelopes

Transmission Type and Scope Pattern	Frequency Spectrum (C: Carrier)	PEV <sub>rms</sub> (arbitrary)	PEP = PEV <sub>2</sub> / Z <sub>0</sub> rms	Average (heating) Power	4391 Series			Model 43
					CW Mode	PEP Mode	%MCD Mode	
CW 		$\frac{100}{\sqrt{2}} V$	100W	100W	100W	100W	0%	100W
AM 100% Mod. 		$\frac{200}{\sqrt{2}} V$	400W	150W	100W	400W	100%	100W
AM 73% Mod. 		$\frac{173}{\sqrt{2}} V$	300W	127W	100W	300W	73%	100W
SSB 1 tone 		$\frac{100}{\sqrt{2}} V$	100W	100W	100W	100W	0%	100W
SSB 2 tone 		$\frac{100}{\sqrt{2}} V$	100W	50W	25W	100W	100%	40.5W
TV Black Level 		$\frac{100}{\sqrt{2}} V$	100W	60W	-	100W	-	9.6W
Pulses 		$\frac{100}{\sqrt{2}} V$	100W	0 W	-	100W	100%	-

Z<sub>0</sub> = 50 ohms PEV: Peak Envelope Voltage. Carrier (or suppressed carrier) PEV was arbitrarily chosen at 100 volts in all examples. PEV<sub>rms</sub> = PEV /  $\sqrt{2}$ .

## Chapter 3

### Installation

The Model 4391A RF Power Analyst is completely portable and very suitable for field or laboratory use. Its power is derived from rechargeable nickel-cadmium batteries inside the unit or from an ac outlet via the power cord supplied with the device.

#### CAUTION

Always be certain the 115/230 voltage selector is set to the proper voltage before ac power is applied.

#### Connections

The Model 4391A contains a short section of rigid 50 ohm coaxial air dielectric transmission line. To make measurements relating to the travelling waves in a coaxial line, that line must be disconnected at some convenient point to permit the Model 4391A air line to be inserted.

Although the Model 4391A is normally supplied with two Female N-type connectors, a variety of easily interchangeable connectors are available to facilitate connecting to the user's system.

Once the Model 4391A is installed in the coaxial line, a Plug-in Element or a pair of Plug-in Elements must be selected which correspond to the frequency and power levels to be measured.

In order to take full advantage of the Model 4391A's capabilities, two elements in a 10:1 ratio of power range should be used. If only one element is used, the other socket should be filled with a dust plug or a higher power element. Also, for greatest accuracy, the element(s) should be chosen having the lowest possible power range that will not result in over-ranging. Table 1 lists elements required for each mode of operation.

Table 1  
 Plug-In  
 Elements  
 Required

Mode	Forward	Reflected
FWD CW	✓	
RFL CW		✓
SWR	✓	✓*
FWD PEP	✓	
RFL PEP		✓
% MOD	✓	
FWD dBm	✓	
RFL dBm		✓
RTN Loss	✓	✓*

\*The reflected element must have a nominal power range one tenth that of the forward element.

The higher power element is placed in the socket marked “FORWARD” and its arrow pointed in the direction of forward power flow (toward antenna or load). The lower power element is placed in the socket marked “REFLECTED” and is normally pointed in the direction opposite to forward power flow.

The elements are clamped in place by the hold-down catches on the face of the line section. These catches must be used to avoid error due to the element not contacting the bottom or seating plate of the socket.

With the element(s) in place, set the range switches to correspond with the nominal power range of the elements. For example, if the forward element is a 5 watt element, the switches are set at 5 and x1. For a 250 watt element they are set at 2.5 and x100. Sometimes it is necessary to use milliwatts or kilowatts as the unit of measure. In other words, 1 watt becomes 10 x 100 milliwatts and 2500 watts becomes 2.5 x 1 kilowatts.



## Chapter 4

### Operating Instructions

#### Operating Modes

The Model 4391A has nine modes of operation which are selected by pressing the mode keys momentarily. In addition, each mode has three output options selected by pressing the modifier keys. Detailed descriptions of the modes and output options follow.

#### Reading Forward Power

For this measurement only a forward element is required. Install the meter and element according to the preceding paragraphs and move the power switch to LINE or BAT depending on the power source desired. When powered up, the Model 4391A always goes into the forward CW power mode. If the unit is already operating, the forward CW power mode is selected by pressing the FWD CW key momentarily. If the applied power exceeds 120 percent of the range, two right-facing arrow heads (i.e., “greater-than” symbols) will be displayed. The operation of this error message does not depend on the correct setting of the range switches by the operator, nor will the meter or its elements be damaged if the switches are incorrectly set.

#### CAUTION

Never apply RF power to the Model 4391A Wattmeter unless both line section sockets are filled with either an element or a dust plug. If an element is used it is advisable to place the element with the arrow at a 90° angle to the coaxial line.

#### CAUTION

Always disconnect ac power before opening the Model 4391A enclosure. Removal of at least one battery cell is also recommended when servicing the instrument.

Figure 5  
Forward Power  
(CW)

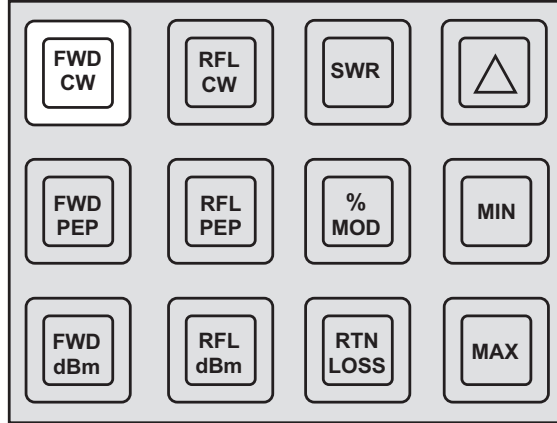

The Model 4391A arrives at values of CW power by a method quite different from analog meters such as the Model 43, also manufactured by Bird Electronic. While the two instruments will agree when the measured wave is of constant amplitude, AM or SSB waves will result in different indications (in the CW mode). This is because the analog instrument uses the inertia of the microammeter to “time-average” the varying signal coming from the element, whereas the Model 4391A uses peak and negative peak detector circuits to measure peak and minimum square root of power and combines them using the equation:

$$\text{CW Power} = \frac{\sqrt{\text{Peak Power}} + \sqrt{\text{Minimum Power}}}{2}^2$$

Using this technique, operation of the CW mode is predictable regardless of envelope shape (see figure 4).

**Reading Re-  
flected CW  
Power**

Operation of the reflected CW power mode is identical to that for forward CW power described above with two exceptions: the readings are taken from the element in the socket marked “REFLECTED” and the range of the element is assumed to be 1/10 the range indicated by the range switches.

Figure 6  
Reflected  
Power (CW)

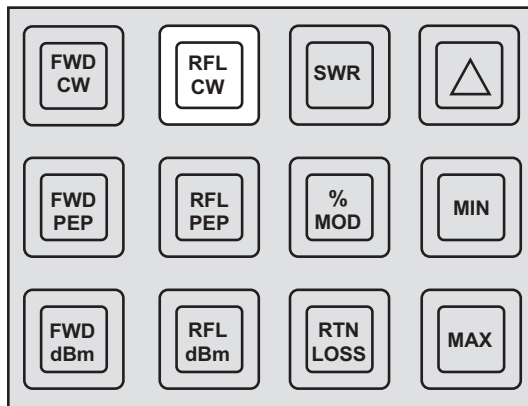

**Reading SWR**

Two elements are required for this mode and they must have a 10 to 1 power range ratio. Press the SWR key momentarily. If the average forward power is between 10 percent and 120 percent of the full scale and the average reflected power is less than 120 percent of the reflected element range, SWR will be displayed. If any of the above conditions are not met, an error message will be displayed. Two arrows pointing to the right — or “greater-than” symbols — indicate over-range, while two left-pointing arrows — or “less-than” symbols — indicate under-range or too little power. Refer to table 2.

Figure 7  
Standing  
Wave Ratio

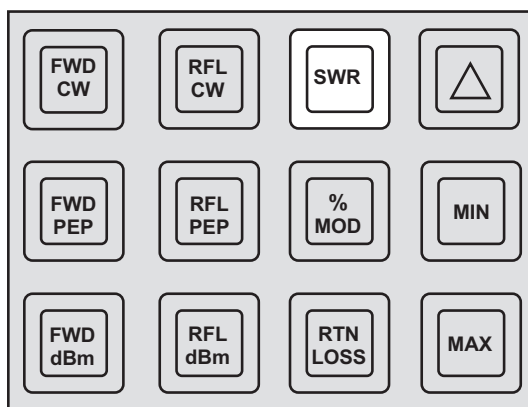

Table 2  
Voltage  
Standing  
Wave Ratio  
(VSWR)

VSWR	Return Loss dB	Reflected Power %
1.01	46.1	0
1.02	40.1	.01
1.03	36.6	.02
1.04	34.2	.04
1.05	32.3	.06
1.06	30.7	.08
1.07	29.4	.11
1.08	28.3	.15
1.09	27.3	.19
1.10	26.4	.23
1.15	23.1	.49
1.20	20.8	.83
1.25	19.1	1.23
1.30	17.7	1.7
1.35	16.5	2.22
1.40	15.6	2.78
1.45	14.7	3.37
1.50	14.0	4.00
1.75	11.3	7.44
2.00	9.50	11.11
2.25	8.30	14.79
2.50	7.40	18.37
2.75	6.60	21.78
3.00	6.00	25.00
3.25	5.50	28.03
3.50	5.10	30.86
3.75	4.70	33.52
4.00	4.40	36.00
4.25	4.20	38.32
4.50	3.90	40.50
4.75	3.70	42.53
5.00	3.50	44.44

**Measuring Peak Envelope Power**

PEP power measurements are made in the same manner as the CW power readings described above, except that the FWD PEP and RFL PEP buttons are pressed and the readings are displayed directly as peak power.

**NOTE:** The accuracy of measurements made with modulation present which has a frequency, duty cycle, pulse width, or repetition rate outside the range of the instrument cannot be assured in any mode of operation.

Figure 8  
Peak Envelope Power (PEP)

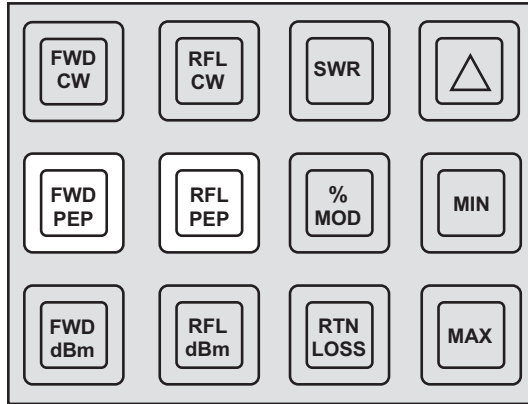

**Measuring Amplitude Modulation**

Only a forward element is required for this mode. The element should be pointed in the direction of forward power and the % MOD key pressed. Modulation is displayed directly in percent, provided the average signal is above 10 percent and the PEP of the signal is below 400 percent of the element's nominal full scale. For specified measurement accuracy, the average CW power levels must be greater than one-third of full scale. Modulation is calculated as follows:

$$\text{Modulation} = \left( \frac{\sqrt{\text{Peak Power}} - \sqrt{\text{Minimum Power}}}{\sqrt{\text{Peak Power}} + \sqrt{\text{Minimum Power}}} \right) \times 100$$

and is therefore limited to the range of 0 to 99.9 percent. Over-modulation will be indicated as 99.9 percent. Refer to table 3.

Figure 9  
Amplitude  
Modulation %

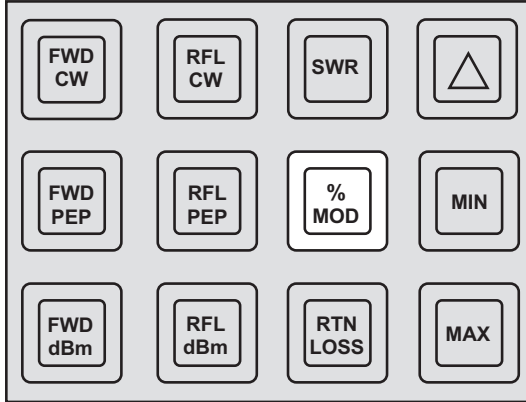

Because of the threshold of the RF diode, a modulated signal which has a minimum power level below 0.3 percent of full scale will result in high modulation reading with uncertain accuracy.

Table 3  
Amplitude  
Modulation

Peak/CW Power	% Modulation
1.00	0
1.10	5
1.21	10
1.32	15
1.44	20
1.56	25
1.69	30
1.82	35
1.96	40
2.10	45
2.25	50
2.40	55
2.56	60
2.72	65
2.89	70
3.06	75
3.24	80
3.42	85
3.61	90
3.80	95
4.00	100

**Measuring Power in dBm**

Operation of the forward and reflected dBm modes is identical to the forward and reflected CW power modes, except that the resulting reading is converted to dB above 1 milliwatt before it is displayed. It should be noted that in doing this conversion, the range set on the slide switches is assumed to be watts rather than kilowatts or milliwatts. If it is not, 30.0 must be added to all dBm readings when the range is in kilowatts, or subtracted from all readings when it is in milliwatts. An error message is displayed if CW power is more than 24 dB below, or peak power is more than 6 dB above the nominal element range.

Figure 10  
CW Power in dBm

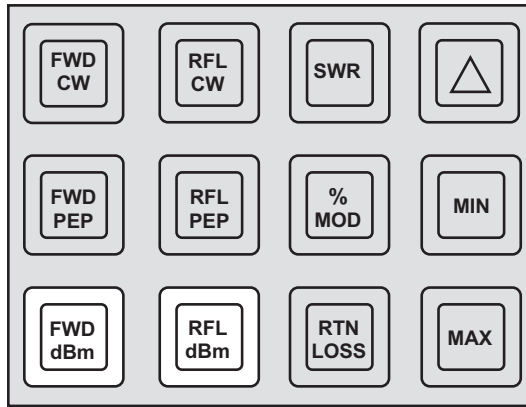

Table 4  
Watts/dBm  
Equivalents

Power	dBm
1 milliwatt	0
10 milliwatts	10
100 Milliwatts	20
1 watt	30
2 watts	33
4 watts	36
10 watts	40
20 watts	43
40 watts	46
100 watts	50

**Measuring Return Loss, Insertion Loss, or Attenuation**

The measurement of return loss is the same as that of SWR except that the result is displayed in dB. In other words a reading of 21.65 indicates that reflected power is 21.6 dB down from forward power.

Figure 11  
Return Loss, Insertion Loss, or Attenuation

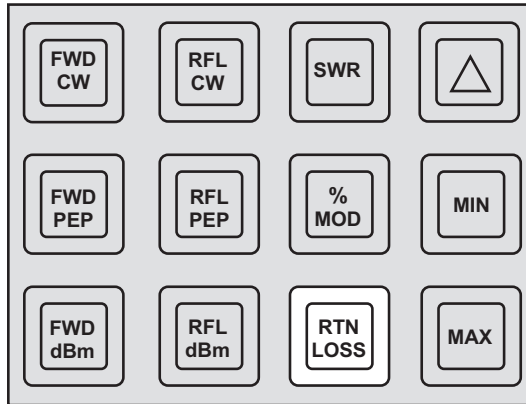

Attenuation or insertion loss can be measured directly using an external single port line section (P/N 4230-006-1), a dc feed-in adapter (P/N 4381-050), and a dc cable (P/N 3170-058-6). The Model 4391A is inserted at the source end of the device being measured. The second line section is inserted at the load end and its dc output is routed by the dc cable to the adapter inserted in the REFLECTED socket of the Model 4391A. Both elements are in this case pointed in the direction of forward power flow. If the two elements do not have a ten to one ratio, a correction factor must be added to or subtracted from the “return loss” reading see table 5, depending on the ratio of the elements.

Table 5  
Correction Factors

Ratio of Elements	Added dB	Ratio of Elements	Added dB
1:1	-10	100:1	10
2:1	-7	200:1	13
2.5:1	-6	250:1	14
4:1	-4	400:1	16
5:1	-3	500:1	17
10:1	0	1000:1	20
20:1	3	2000:1	23
25:1	4	2500:1	24
40:1	6	4000:1	26
50:1	7	5000:1	27



**Monitoring Maximum and Minimum Readings**

While operating in any of the modes described, the Model 4391A will continuously keep track of the highest and lowest reading obtained. This action begins after ten reading cycles to allow time for the peak detectors to settle from the previous mode.

To recall the maximum or minimum reading, depress and hold the MAX or MIN key. When these keys are released, the meter goes back to displaying the current value of the parameter being measured. Recalling maximum or minimum does not stop the meter from continuing to monitor the current value and updating the minimum and maximum registers. To clear the minimum and maximum register, the mode key must be pressed again or a new mode selected. For example, if CW power deviations are to be monitored, the Model 4391A is installed as described at the beginning of this section and turned on, then the power source is turned on and allowed to stabilize. Once the system has stabilized, and the FWD CW key is pressed to clear the MAX and MIN registers. At any time during test the MAX and MIN keys can be used to recall the maximum and minimum values without affecting the test. However, pressing the FWD CW key or changing modes will clear the registers.

Figure 12  
Maximum or Minimum Readings

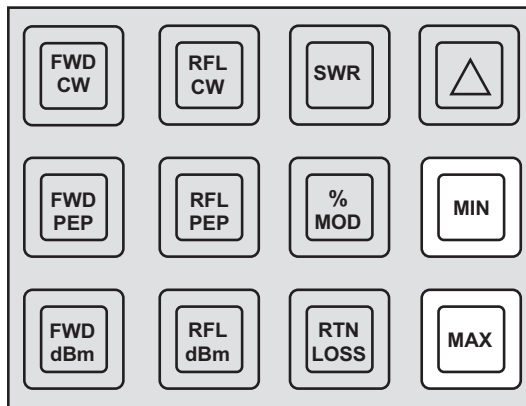

**Using the Peaking Aid**

The peaking aid is useful for making adjustments to optimize any of the parameters which the Model 4391A measures. After the mode is selected, the delta ( ) key is pressed momentarily. This blanks the least significant digit of the display, and replaces it with a right-facing arrow head if the measured quantity is increasing or a left-facing arrow head if it is decreasing. If there is no change, the digit is left

blank. To find a peak, begin making the adjustment in whichever direction produces a right-facing arrow head and continue slowly in that direction until the arrow head turns around. At this point the peak has been reached. To check to make sure the peak has not been passed, press the MAX key to read the highest value read and release it to read the current value. The two should be the same. Desired minimum levels (e.g. of reflected power or of SWR) are found in a similar manner.

Figure 13  
Peaking Aid  
(Δ)

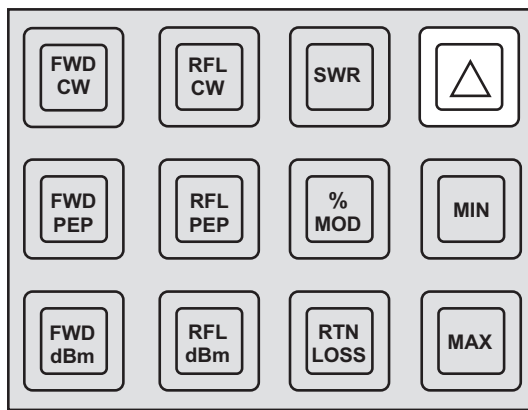

**CAUTION**  
Always be certain the 115/230 voltage selector is set to the proper voltage before ac power is applied.

**Operating on AC Power**

For ac power operation, the Model 4391A is simply connected to an ac receptacle using the line cord provided. The correct ac voltage is selected via a rear panel switch. The meter may be operated in this manner with the batteries removed if desired. Refer to figure 14.

Figure 14  
Rear Panel

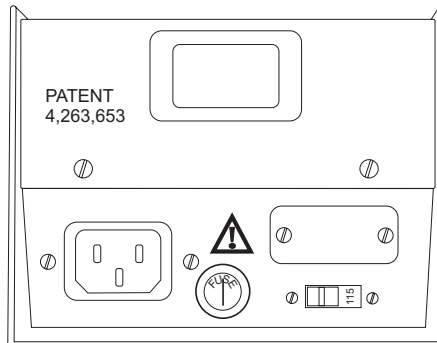

## **Chapter 5**

---

## **Maintenance**

Due to its complexity, repair of the Model 4391A is recommended only for authorized service personnel. For any repairs that can not be completed in the field return the unit to the authorized service center listed below.

**Service Center**

**U.S.A. Sales and Manufacturing**  
Service Group  
Bird Electronic Corporation  
30303 Aurora Road  
Cleveland (Solon), Ohio 44139-2794  
Phone: (440) 248-1200  
Fax: (440) 248-5426

**Sales Offices**

For the location of the sales offices nearest you, give us a call or visit our web site at:

<http://www.bird-electronic.com>

## Troubleshooting

### CAUTION

The Model 4391A Wattmeter contains MOS (metal oxide semiconductor) integrated circuits which may be damaged by static electricity. Open the housing only when sure that there are no static producing materials such as carpeting or styrofoam where the work is to be done. Work on a conductive, grounded work surface touching it frequently to discharge static from your body. If a part is to be stored or shipped, wrap it in conductive packaging materials designed for static sensitive circuitry.

#### **Worn or Damaged Connectors**

This problem can result in high standing waves. Inspect the connectors visually and replace if required.

#### **Worn Element Seats**

The element seat is not plated as manufactured so visual inspection is of little value in detecting this problem. A badly worn seat will cause an element to read 1 or 2 percent higher than it does in a new line section with power held constant. Remedy by replacing the line section.

#### **Intermittent Contact**

Touching or slightly rotating the element causes large changes in the reading. Clean the contacts on the element and in the sockets of the line section with a mild cleaning solvent such as alcohol. If the contacts in the line section are recessed too far, bend them out slightly with a small screwdriver. Take care not to bend them out so far as to interfere with the insertion of the element.

#### **Loose Catches**

If a catch is loose, the element can be rotated easily and may rock slightly under light finger pressure, resulting in loss of accuracy. This problem can usually be repaired by bending the catch slightly. If not, the line section must be replaced.

#### **No Output From One Socket**

This can result either from a poor contact as described above, or a faulty connection, or short between the line section and the MCU and analog PC board. Check with a VOM and repair.

#### **Short Battery Life**

If the batteries lose their ability to hold a full charge, they should be replaced with new batteries available from Bird. Note that any C-size nickel-cadmium battery may be used.

<b>Unit Will Not Operate at All Under Battery Power</b>	This condition probably results from a bad connection. Check all battery connections with a VOM and repair the bad connection.
<b>Does Not Function In Line Position</b>	Check for open fuse, broken line cord, or 115/230 selector switch set incorrectly.
<b>Key Does Not Make Contact</b>	If only one key is not working, the problem is in the keyboard. Replace the keyboard.
<b>Row or Column of Keys Not Working</b>	This is likely to be caused by an open or short circuit inside the keyboard or between the keyboard and the computer chip. Remedy by locating short or open and correcting it.
<b>One Segment on One Digit Out</b>	This can only be caused by a defective LED display, its socket, or an open connection where the socket is soldered to the PC board. Switch displays to isolate the problem.
<b>Entire Digit Malfunction</b>	This is usually caused by a fault in the drive circuitry to the digit. If the keyboard is malfunctioning, check for a short or an open between the microcomputer chip and the drive transistors for the digit readout.
<b>Same Segment on All Digits Malfunctioning</b>	This problem can only be caused by a defective 7447 driver IC or a short or open between the driver and the displays.
<b>No Decimal Point or All Decimal Points</b>	The decimal point is driven by a PNP transistor near the 7447 IC. A short or open on either side of this transistor can cause the problem. Note - An all decimal point display may indicate low supply voltage or a defect in the supply voltage circuitry. The dc input at the power switch should measure at least 7.0 volts dc.
<b>Strange Counting Sequence</b>	If this happens, there is a problem in the binary coded decimal signal coming from the computer chip to the driver IC. Isolate the problem and repair. The 7447 IC may be at fault.

## Disassembly

### CAUTION

The Model 4391A Wattmeter contains MOS (metal oxide semiconductor) integrated circuits which may be damaged by static electricity. Open the housing only when sure that there are no static producing materials such as carpeting or styrofoam where the work is to be done. Work on a conductive, grounded work surface touching it frequently to discharge static from your body. If a part is to be stored or shipped, wrap it in conductive packaging materials designed for static sensitive circuitry.

#### Front Panel Removal

To take off the front panel, first loosen but do not remove the six 4-40 oval head screws on each side of the housing. Then remove the six 4-40 pan head screws and four 6-32 pan head screws holding the front panel on. The front panel may now be carefully pulled up at its upper end (to clear the line sections blocks), then simply lifted out from the case.

The main PC board can be tilted upwards by removing the front four of the six 4-40 oval head screws securing its mounting rails. These screws hold the mounting rails to the inside of the case and are located on each side of the housing just below the top edge. The back two screws, just above the RF connectors, although loosened, remain in place. This board must be removed completely in order to remove the line section.

#### Removing the Line Section

Remove the eight pan head screws holding the QC connectors and remove the connectors. Remove the four oval head screws which hold the line section to the sides of the case. Using finger pressure, spread the case open just enough to pull the line section straight up and out.

#### Removing the Line Section PC Board

Remove the four screws holding the PC board to the line section. Pull the board straight away from the line. Note the positions of the spacers and white Teflon beads for reassembly.

#### Decreasing the Settling Time

When low duty cycle and low repetition rate pulse measurements are not required, resistors R09 and R10 on the line section PC board can be changed to 4.7 M and 2.2 M , 1/4 watts, respectively. This halves the settling time while maintaining good rejection of 50 to 60 Hz noise.

## Calibration

Calibration of the Model 4391A is accomplished by using a direct current source. Equipment required is an adjustable current source, or a battery with a multiple turn potentiometer, connected in series with its leads, capable of supplying 30 microamperes into a 1400 ohm load, and a 4-1/2 digit microammeter. A dc feed in adapter P/N 4381-050 is also useful and is recommended.

Connect the negative side of the current source to the body of the line section in the Model 4391A. Connect the positive side of the current source to the positive terminal of the microammeter. The negative terminal lead of the microammeter is attached to the wiper contact in the forward element socket of the line section. If the dc adapter, P/N 4381-050, is used, the negative side of the current source is connected to the outer conductor of the BNC connector and the lead from the negative terminal of the microammeter goes to the BNC center contact.

Set the Model 4391A range switches to the 10 and x100 settings. Turn the unit on and select the forward CW mode. Adjust the current source until the microammeter indicates 30.00  $\pm$  0.05 microamperes. The Model 4391A display should now read 1000 . If the display shows an error greater than the 5 tolerance, remove the front panel. Adjust the calibration potentiometer, located just below the forward element socket, until a reading of exactly 1000 is obtained.

No other calibration is required. For maximum accuracy, calibration should be checked, and the unit recalibrated if necessary, at least once a year.

## Repair

Repair is limited to replacing defective parts with new ones. Refer to parts list for a complete list of parts used in the Model 4391A. Use of parts not specified in the parts list is not recommended.



### Fuse Replacement

Always use the same type and rating of fuse when replacing the fuse. Fuse information can be found in the replacement parts list on page 29.

## Battery Replacement

**WARNING**

Be sure that the power cable is unplugged before opening the wattmeter case. The power supply capacitor, C11, can retain a dangerous charge that must be removed before touching. Always have another person standing by who is trained in electric shock first aid.

**WARNING**

Units are equipped with rechargeable batteries. These are to be replaced by authorized service personnel only.

1. With the front panel removed, unscrew four lower phillips oval head screws, and remove four countersunk lockwashers. Loosen the two remaining screws.
2. Tilt the main PC board assembly up to expose the batteries.
3. Peel apart velcro strap as illustrated in figure 15. Remove six batteries and three battery tubes from the battery holder.
4. Install six new batteries and three battery tubes into the battery holder. Be sure to observe proper polarity.
5. Feed the loose end of velcro strap through the D-ring. Tighten the strap until the batteries are held firmly into place. Secure the strap by pressing firmly into place.
6. Lower the PC board assembly and align the mounting holes. Secure the PC board to the lower housing with four phillips oval head screws and four countersunk lockwashers. Tighten the two remaining screws.
7. Charge the batteries for 14 hours before using the Model 4391A.



**Battery Care**

With average use, the nickel-cadmium batteries in the Model 4391A will power the unit for eight hours before recharging is required. The Model 4391A will maintain its rated accuracy until all the decimal points light, indicating recharging is required. Recharging is accomplished by connecting ac power to the unit. This takes approximately 14 hours when the unit is turned off, or 24 hours when it is operating in the LINE position. To prolong the life of the batteries, it is recommended that they be allowed to discharge until the decimal points light periodically before recharging. If the batteries lose the ability to hold a charge they can be replaced with standard C-size nickel-cadmium batteries. See Chapter-5, Maintenance for important precautions regarding static electricity when opening the housing.

Figure 15  
Battery  
Replacement

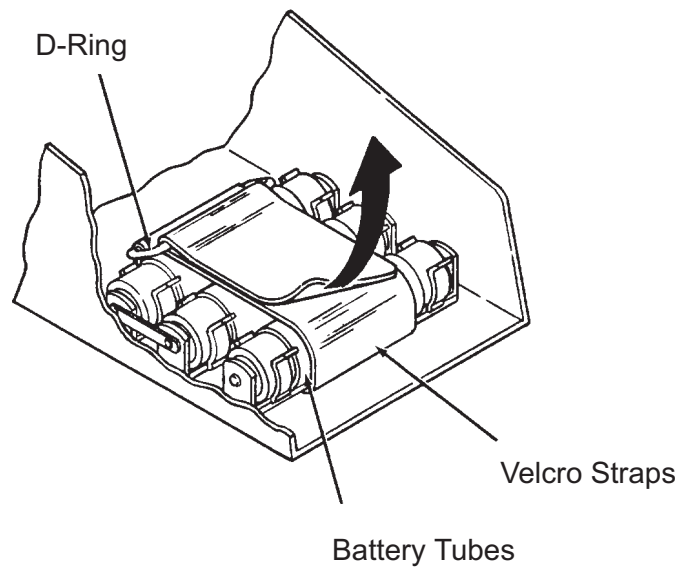
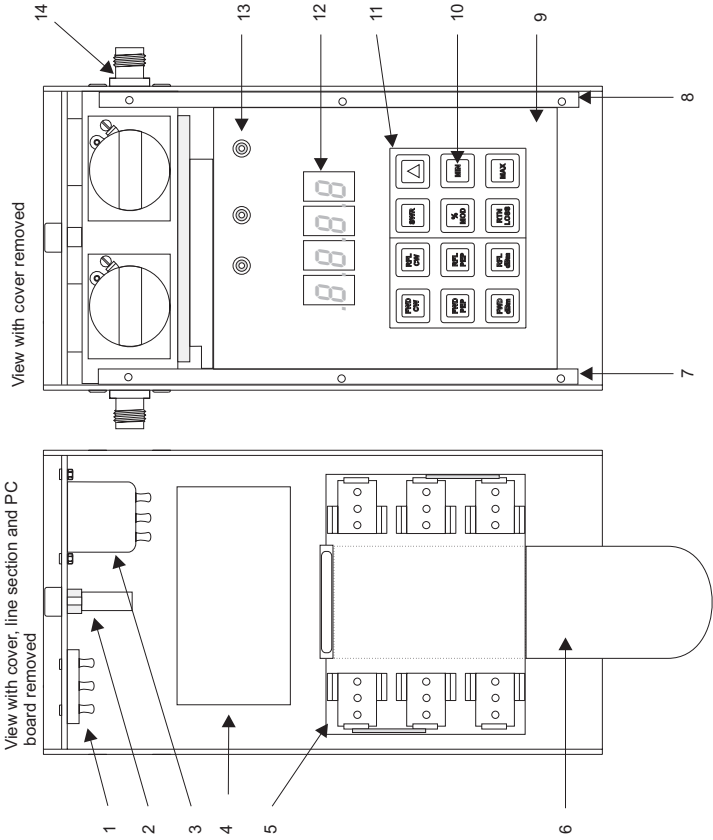

Figure 16  
Parts  
Drawing



---

**Replacement Parts List**

<b>Item no.</b>	<b>Qty.</b>	<b>Description</b>	<b>Part Number</b>
1	1	Slide Switch	5A2317
2	1	Fuse holder, 5 X 20mm	5-1584
N/S	1	Fuse, Slo-Blo, IEC 1/8 Amp	5A2257-7
3	1	Power line filter	5-1582
4	1	PC Board assy., (includes recitifier circuit)	4391-041
5	1	Battery holder	4391-019
N/S	6	Batteries (rechargeable) "C" cell	5-1230
6	1	Velcro strap	5-1958
7	1	PCB Support, Left	4391-024
8	1	PCB Support, Right	4391-025
9	1	PC Board processor assembly	4391-007
10	1	Keyboard legend	4386-012
11	2	Keyboard module	5-1277
12	4	(DS1-DS4) LED display	5-1337
13	3	SPDT toggle switch	5-1327
14	2	Connector, QC F-N	4240-062
N/S	2	Dust Plug	3610-031
N/S	1	Display bezel	4381-060
N/S	1	Red filter	4381-061
N/S	1	I/O cable assembly	4380-514
N/S	6	Pushnut	5-1076-2
N/S	1	Bail	4381-012

N/S = Not Shown

Figure 17  
Line  
Section  
Assembly

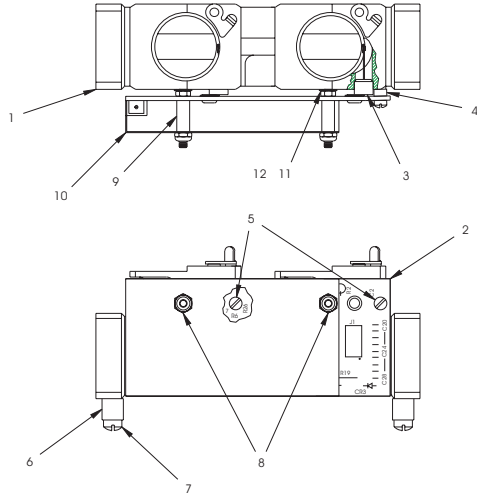

Item No.	Qty.	Description	Part Number
1	1	Line Section Complete	4391-014
1A	1	Line Section without PC board	4381-005
2	1	PC Board assembly	4391-005
3	2	Bead, Keying	4391-026
4	2	Spacer	4391-027
5	2	Screw, 8-32 x1/2 Stainless Steel	Commercial
6	2	Support	4381-029
7	4	Screw, 4-40 x 1/4 Stainless Steel	Commercial
8	2	Hex nut with nylon insert 4-40 Stainless Steel	Commercial
9	2	Spacer	4391-035-1
10	1	Cover, PC Board	4391-034
11	2	Internal Tooth #4 Lockwasher	Commercial
12	2	Threaded Standoff	4391-038

### **Limited Warranty**

All products manufactured by Seller are warranted to be free from defects in material and workmanship for a period of one (1) year, unless otherwise specified, from date of shipment and to conform to applicable specifications, drawings, blueprints and/or samples. Seller's sole obligation under these warranties shall be to issue credit, repair or replace any item or part thereof which is proved to be other than as warranted; no allowance shall be made for any labor charges of Buyer for replacement of parts, adjustment or repairs, or any other work, unless such charges are authorized in advance by Seller.

If Seller's products are claimed to be defective in material or workmanship or not to conform to specifications, drawings, blueprints and/or samples, Seller shall, upon prompt notice thereof, either examine the products where they are located or issue shipping instructions for return to Seller (transportation-charges prepaid by Buyer). In the event any of our products are proved to be other than as warranted, transportation costs (cheapest way) to and from Seller's plant, will be borne by Seller and reimbursement or credit will be made for amounts so expended by Buyer. Every such claim for breach of these warranties shall be deemed to be waived by Buyer unless made in writing within ten (10) days from the date of discovery of the defect.

The above warranties shall not extend to any products or parts thereof which have been subjected to any misuse or neglect, damaged by accident, rendered defective by reason of improper installation or by the performance of repairs or alterations outside of our plant, and shall not apply to any goods or parts thereof furnished by Buyer or acquired from others at Buyer's request and/or to Buyer's specifications. In addition, Seller's warranties do not extend to the failure of tubes, transistors, fuses and batteries, or to other equipment and parts manufactured by others except to the extent of the original manufacturer's warranty to Seller.

The obligations under the foregoing warranties are limited to the precise terms thereof. These warranties provide exclusive remedies, expressly in lieu of all other remedies including claims for special or consequential damages. SELLER NEITHER MAKES NOR ASSUMES ANY OTHER WARRANTY WHATSOEVER, WHETHER EXPRESS, STATUTORY, OR IMPLIED, INCLUDING WARRANTIES OF MERCHANTABILITY AND FITNESS, AND NO PERSON IS AUTHORIZED TO ASSUME FOR SELLER ANY OBLIGATION OR LIABILITY NOT STRICTLY IN ACCORDANCE WITH THE FOREGOING.

# DECLARATION OF CONFORMITY

Manufacturer: Bird Electronic Corporation  
30303 Aurora Road  
Cleveland, Ohio 44139-2794

Product: Thruline Wattmeter

Models: 4391A

The undersigned hereby declares, on behalf of Bird Electronic Corporation of Cleveland, Ohio, that the above-referenced product, to which this declaration relates, is in conformity with the provisions of the following standards;

EN 55011:1991 - Conducted and Radiated Emissions (Class B)  
EN 61000-3-2:1995 - Harmonic Emissions  
EN 50082-2:1997 - Generic Immunity

These standards are in accordance with EMC Directive (89/336/EEC).

European Standard EN 61010-1:1993 - Part 1: General Requirements  
Including Amendment 2:1995

This standard is in accordance with Low Voltage Directive (73/23/EEC). 1973

The technical documentation file required by this directive is maintained at the corporate headquarters of Bird Electronic Corporation, 30303 Aurora Road, Cleveland, Ohio 44139.



Bob Gardiner  
Director of Quality  
Bird Electronic Corporation